

Kalmar Abig



- Dimensioni espresse in millimetri
- Potenza espressa in Watt a $\Delta T 50^\circ$
- Radiatore in alluminio
- Prezzo per batteria in tutte le finiture RAL
- Big One da un elemento, collega solo con valvola "One" descritta in figura e da noi fornita compresa nel prezzo.

Monotubo / Single element

*Dimension expressed in millimetres
Output expressed in Watt at $\Delta T 50^\circ$
Aluminium radiator
Price per piece in all RAL finishes
Big one single element, connect only with "One" valve included in the price as shown in picture.*



KALMAR
concept in aluminium

www.kalmar.waw.pl

| Modello <i>Model</i> | elementi <i>elements</i> | profondità <i>depth</i> | larghezza <i>width</i> | potenza <i>output</i> | interasse <i>center</i> | finitura colorata <i>coloured version</i> | finitura satinata o lucida <i>satin or polished version</i> |
|-------------------------|-----------------------------|----------------------------|---------------------------|--------------------------|----------------------------|--|--|
| H 1800 | 1 | 140 | 140 | 468 | 40 | | |

ACCESSORI - ACCESSORIES

Valvola e detentore mod. "Abig monotubo"
(inclusa nel kit versione manuale)
Valve and lockshield mod. "Abig single element"
(included in manual version kits)

Coppia raccordi per connessioni all'impianto tubi rame
Connection fittings for copper pipe, pair

ACCESSORI PER VERSIONE ELETTRICA ACCESSORIES FOR ELECTRIC VERSION

Resistenza elettrica 450 Watt
Electric element 450 Watt

Liquido di riempimento
Liquid for filling

*In sede d'ordine é importante specificare il tipo di raccordo (ferro, rame, multistrato o polyetilene) e il suo diametro.

* While ordering, it's important to specify fittings type (for iron, copper, multilayer or plastic pipes) and their diameter

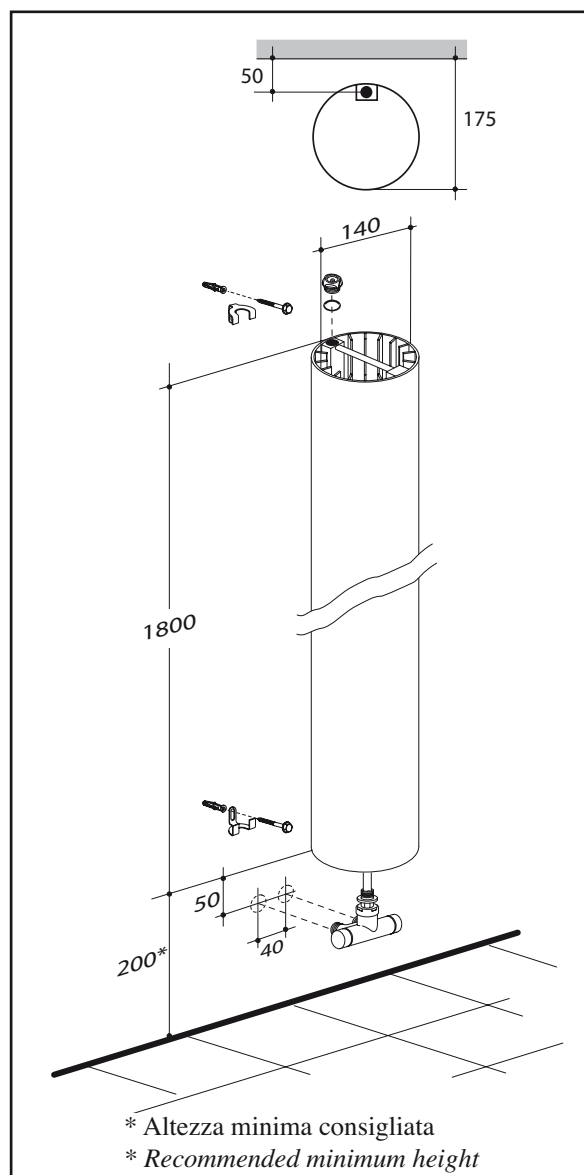

Kalmar Abig



- Dimensioni espresse in millimetri
- Potenza espressa in Watt a ΔT 50°
- Radiatore in alluminio
- Prezzo per batteria in tutte le finiture RAL

*Dimension expressed in millimetres
Output expressed in Watt at ΔT 50°
Aluminium radiator
Price per piece in all RAL finishes*

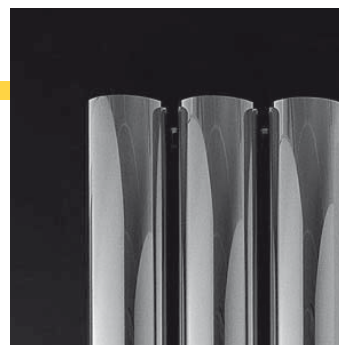

KALMAR
concept & industry

www.kalmar.eu.pl

| Modello <i>Model</i> | elementi <i>elements</i> | profondità <i>depth</i> | larghezza <i>width</i> | potenza <i>output</i> | interasse <i>center</i> | finitura colorata <i>coloured version</i> | finitura satinata o lucida <i>satin or polished version</i> |
|-------------------------|-----------------------------|----------------------------|---------------------------|--------------------------|----------------------------|--|--|
| H 1800 | 2 | 170,5 | 290 | 936 | 1740 | | |
| H 1800 | 3 | 170,5 | 440 | 1404 | 1740 | | |
| H 1800 | 4 | 170,5 | 590 | 1872 | 1740 | | |
| H 1800 | 5 | 170,5 | 740 | 2340 | 1740 | | |
| H 600 | 4 | 170,5 | 590 | 844 | 540 | | |
| H 600 | 5 | 170,5 | 740 | 1055 | 540 | | |
| H 600 | 6 | 170,5 | 890 | 1266 | 540 | | |
| H 600 | 8 | 170,5 | 1190 | 1688 | 540 | | |

ACCESSORI - ACCESSORIES

Valvola mod. "Twin" + testa termostatica
(finitura cromo)
"Twin" valve + thermostatic head
(chrome version)

Valvola e detentore mod. "Cilindro"
(finitura cromo)
Valve and lockshield mod. "Cilindro"
(chrome version)

Coppia raccordi per connessioni all'impianto
tubi rame
Connection fittings for copper pipe, pair

RACCORDI - CONNECTIONS

Collegamento standard 100 - 300 - 110 - 310
Standard connection 100 - 300 - 110 - 310



Possibilità di collegamento tipo 120 - 320 - 430, inserendo
il diaframma fornito nel kit.
*Connections 120 - 320 - 430, are possible by mounting the
diaphragm.*

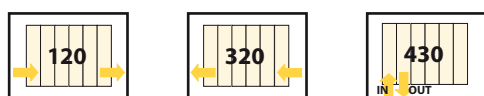

*In sede d'ordine é importante specificare il tipo di raccordo (ferro, rame,
multistrato o polyetilene) e il suo diametro.

* *While ordering, it's important to specify fittings type (for iron, copper,
multilayer or plastic pipes) and their diameter*

