

Kalmar Antykwa O

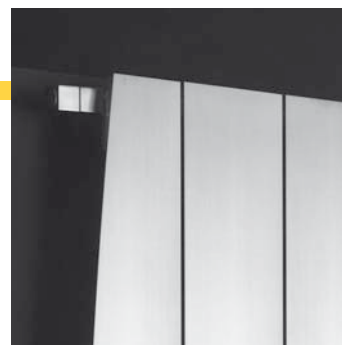

- Dimensioni espresse in millimetri
- Potenza espressa in Watt a ΔT 50°
- Radiatore in alluminio
- Prezzo per batteria in tutte le finiture RAL

*Dimension expressed in millimetres
Output expressed in Watt at ΔT 50°
Aluminium radiator
Price per piece in all RAL finishes*



KALMAR
energia e calore

www.kalmar.waw.pl

Modello Model	profondità depth	larghezza width	altezza height	potenza output	interasse center	finitura colorata coloured version	finitura satinata o lucida satin or polished version
H 700/6	60	925	700	464	640		
H 1800/5	60	770	1800	1740			

ACCESSORI - ACCESSORIES

Valvola e detentore mod. "Cilindro"
(finitura cromo)
*Valve and lockshield mod. "Cilindro"
(chrome version)*

Coppia raccordi per connessioni all'impianto
tubi rame
Connection fittings for copper pipe, pair

Valvola mod. "Cilindro" + testa termostatica
(finitura cromo)
*Valve mod. "Cilindro" + thermostatic head
(chrome version)*

RACCORDI - CONNECTIONS

Collegamento standard 100 - 300 - 110 - 310
Standard connection 100 - 300 - 110 - 310

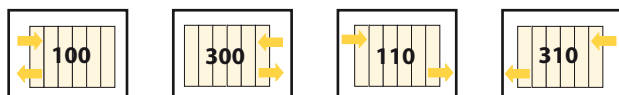

Possibilità di collegamento tipo 120 - 320, inserendo il diaframma fornito nel kit.
Connections 120 - 320, are possible by mounting the diaphragm.

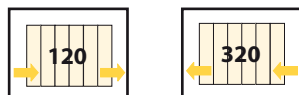

*In sede d'ordine é importante specificare il tipo di raccordo (ferro, rame, multistrato o polyetilene) e il suo diametro.

* While ordering, it's important to specify fittings type (for iron, copper, multilayer or plastic pipes) and their diameter.

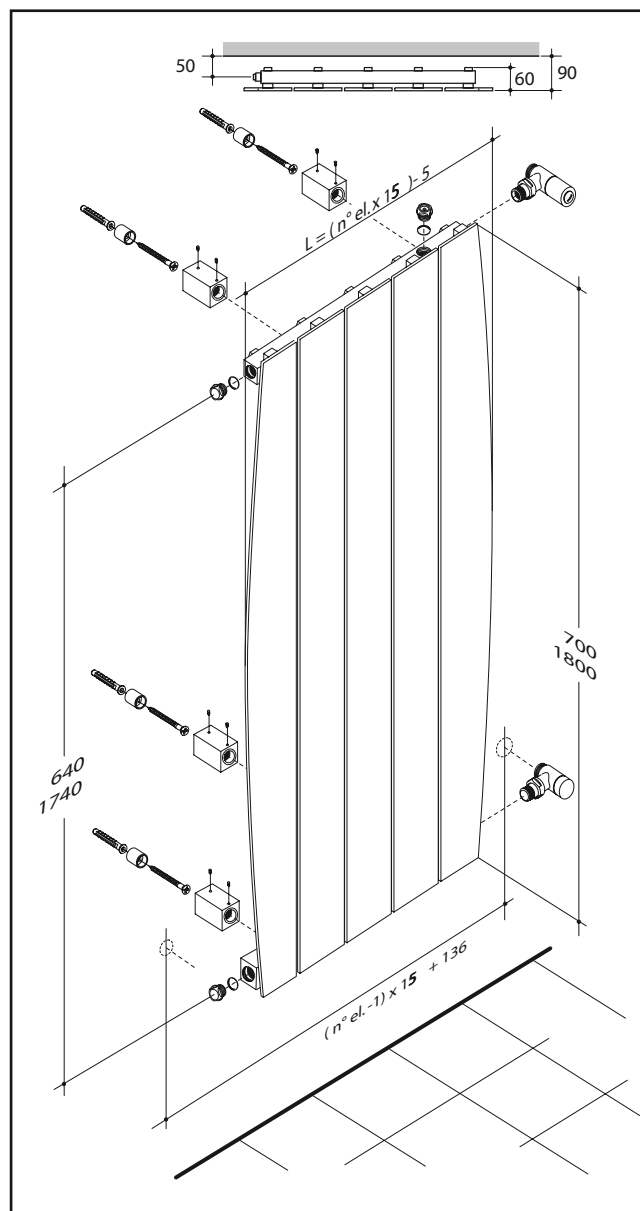

Kalmar Antykwa S



- Dimensioni espresse in millimetri
- Potenza espressa in Watt a ΔT 50°
- Radiatore in alluminio
- Prezzo per batteria in tutte le finiture RAL

*Dimension expressed in millimetres
Output expressed in Watt at ΔT 50°
Aluminium radiator
Price per piece in all RAL finishes*

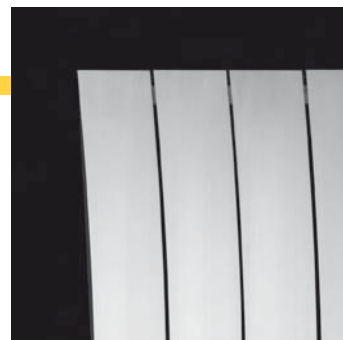

KALMAR
concept. the reality

www.kalmar.waw.pl

Modello Model	profondità depth	larghezza width	altezza height	potenza output	interasse center	finitura colorata coloured version	finitura satinata o lucida satin or polished version
H 1500/5	60	570	1500	827	1440		
H 1800/6	60	675	1800	1740			

ACCESSORI - ACCESSORIES

Valvola e detentore mod. "Cilindro"
(finitura cromo)
*Valve and lockshield mod. "Cilindro"
(chrome version)*

Coppia raccordi per connessioni all'impianto
tubi rame
Connection fittings for copper pipe, pair

Valvola mod. "Cilindro" + testa termostatica
(finitura cromo)
*Valve mod. "Cilindro" + thermostatic head
(chrome version)*

RACCORDI - CONNECTIONS

Collegamento standard 100 - 300 - 110 - 310
Standard connection 100 - 300 - 110 - 310

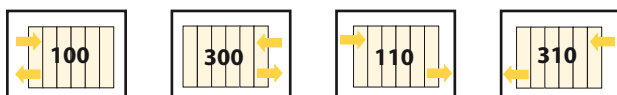

Possibilità di collegamento tipo 120 - 320, inserendo il diaframma fornito nel kit.
Connections 120 - 320, are possible by mounting the diaphragm.

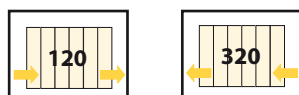

*In sede d'ordine é importante specificare il tipo di raccordo (ferro, rame, multistrato o polyetilene) e il suo diametro.

* While ordering, it's important to specify fittings type (for iron, copper, multilayer or plastic pipes) and their diameter.

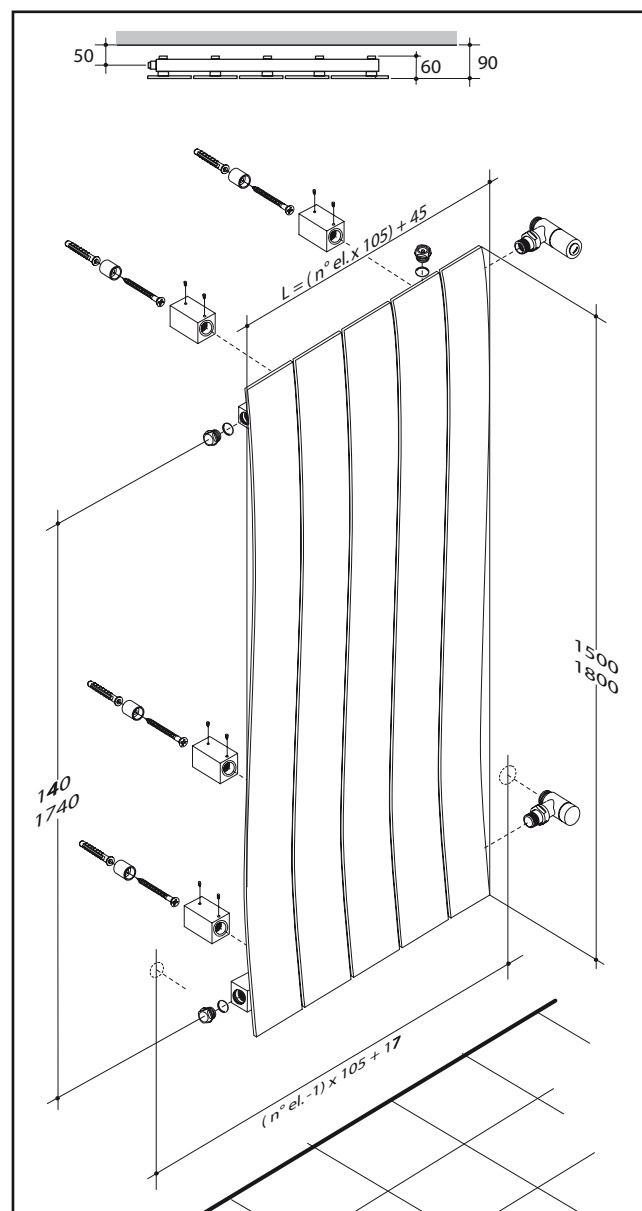

Kalmar Antykwa X



- Dimensioni espresse in millimetri
- Potenza espressa in Watt a ΔT 50°
- Radiatore in alluminio
- Prezzo per batteria in tutte le finiture RAL

*Dimension expressed in millimetres
Output expressed in Watt at ΔT 50°
Aluminium radiator
Price per piece in all RAL finishes*

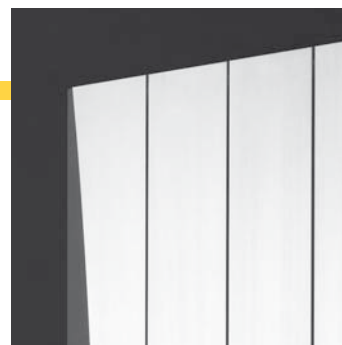

KALMAR
concept. the history

www.kalmar.eu.pl

Modello Model	profondità depth	larghezza width	altezza height	potenza output	interasse center	finitura colorata coloured version	finitura satinata o lucida satin or polished version
H 1800/4	60	615	1800	776	1740		
H 1800/5	60	770	1800	995	1740		

ACCESSORI - ACCESSORIES

Valvola e detentore mod. "Reversa"
(finitura cromo; non sostituibile con altri modelli)
*Valve and lockshield mod. "Reversa"
(chrome version; it is not changeable with other models)*

Coppia raccordi per connessioni all'impianto
tubi rame
Connection fittings for copper pipe, pair

RACCORDI - CONNECTIONS

Collegamento standard 100 - 300 - 110 - 310
Standard connection 100 - 300 - 110 - 310

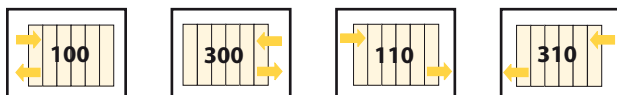

Possibilità di collegamento tipo 120 - 320, inserendo il diaframma fornito nel kit.

Connections 120 - 320, are possible by mounting the diaphragm.

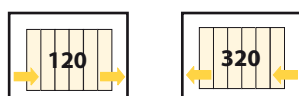

*In sede d'ordine é importante specificare il tipo di raccordo (ferro, rame, multistrato o polyetilene) e il suo diametro.

** While ordering, it's important to specify fittings type (for iron, copper, multilayer or plastic pipes) and their diameter.*

