

Fitting Instruction-Proxima R

Code:01.08.001-01

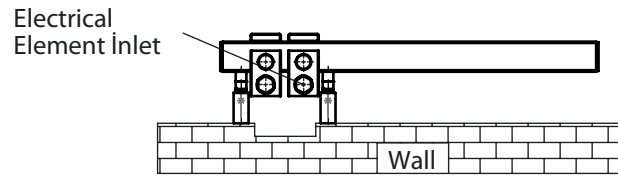

MODEL NAME	A HEIGHT mm	B LENGTH mm	C PIPE CENTER mm	D VERTICAL BRACKET CENTERS mm	E HORIZONTAL BRACKET CENTERS mm	HEAT OUTPUTS (BTU) Delta T:50 °C	HEAT OUTPUTS (WATT) Delta T:50 °C
Proxima 10-R	920	500	50	830	115	3197	936
Proxima 15-R	1460	500	50	1370	115	5328	1560

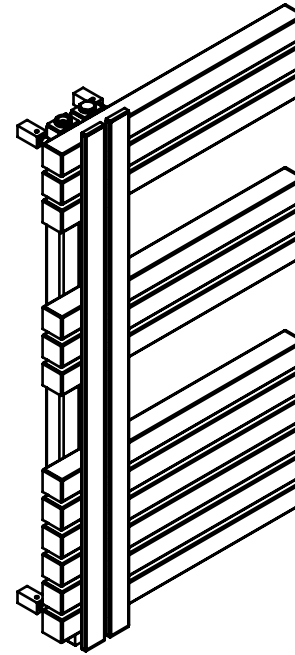
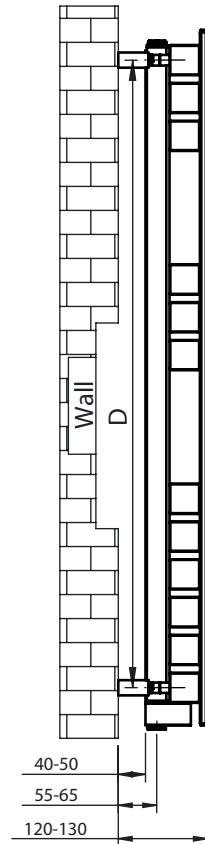
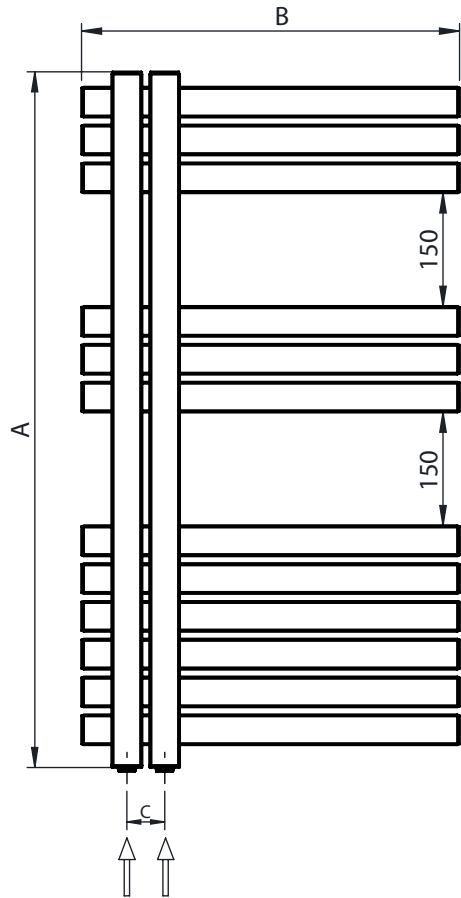

Bracket Assembly

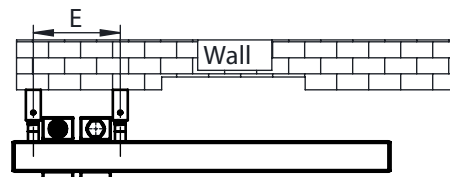
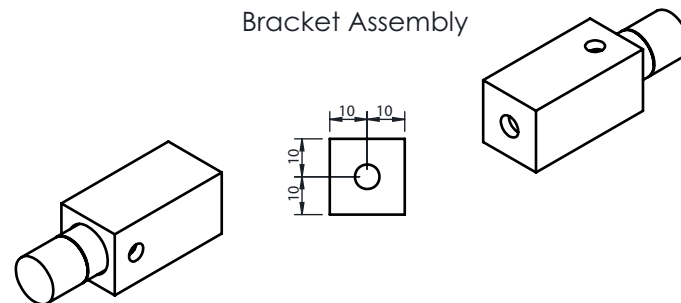

Fitting Instruction-Proxima L

Code:01.08.002-01

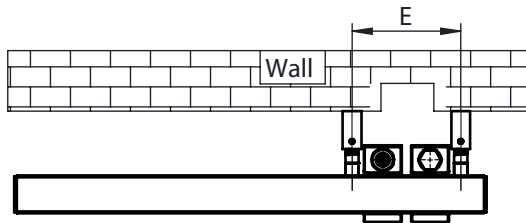
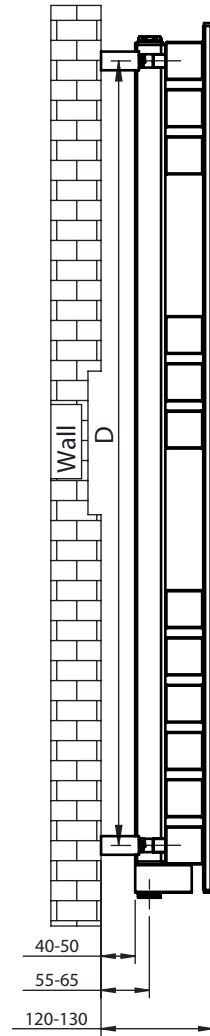
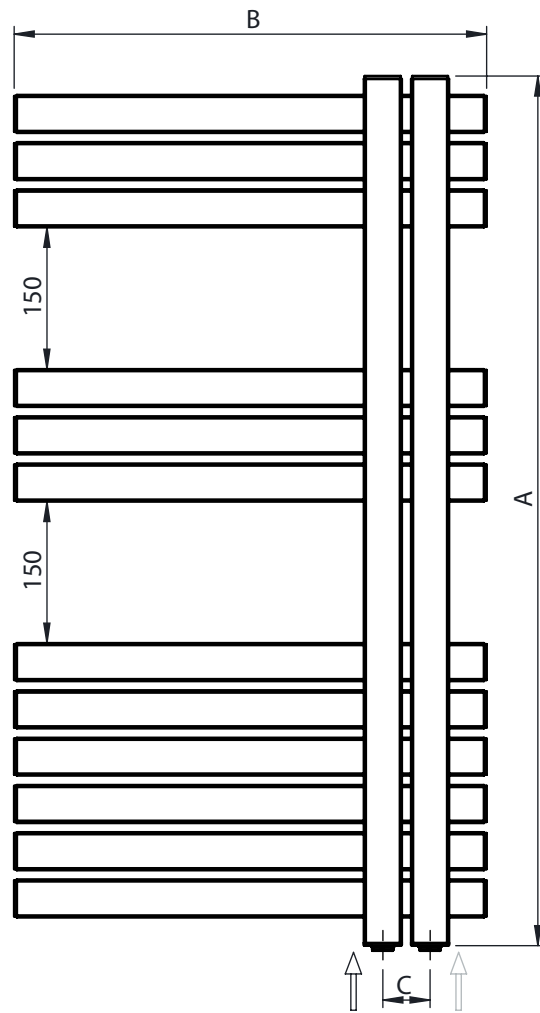

MODEL NAME	A	B	C	D	E	HEAT OUTPUTS (BTU)	HEAT OUTPUTS (WATT)
	HEIGHT mm	LENGTH mm	PIPE CENTER mm	VERTICAL BRACKET CENTERS mm	HORIZONTAL BRACKET CENTERS mm	Delta T:50 °C	Delta T:50 °C
Proxima 10-L	920	500	50	830	115	3197	936
Proxima 15-L	1460	500	50	1370	115	5328	1560

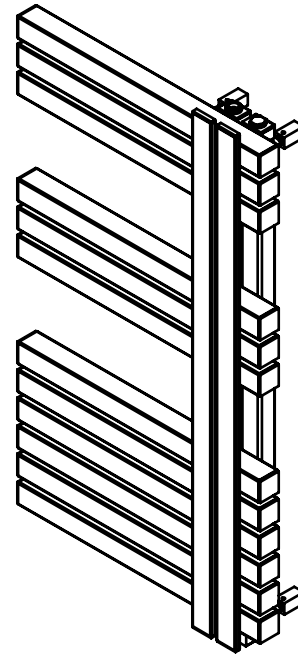

Bracket Assembly

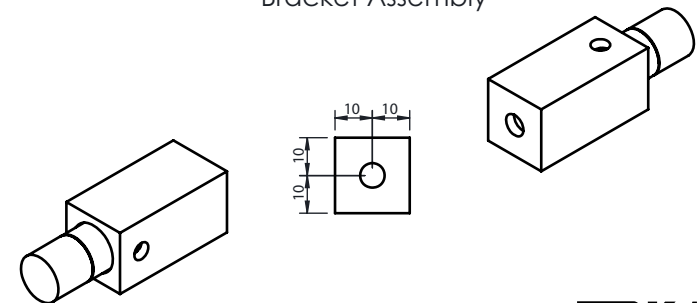

Fitting Instruction-Proxima R

Code:01.08.005-01

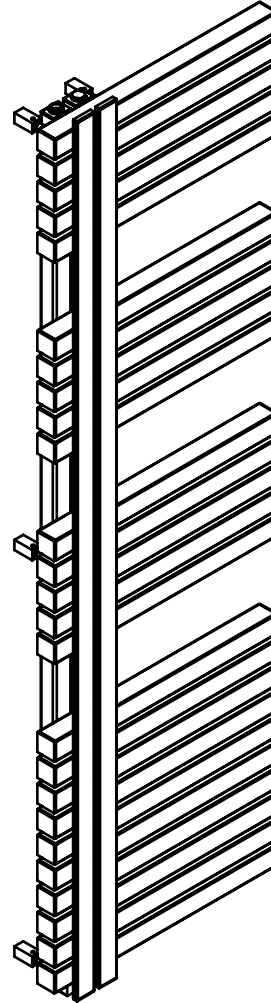
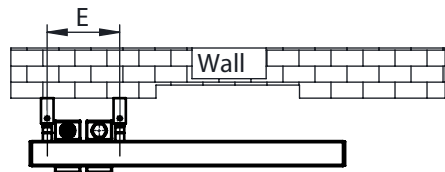
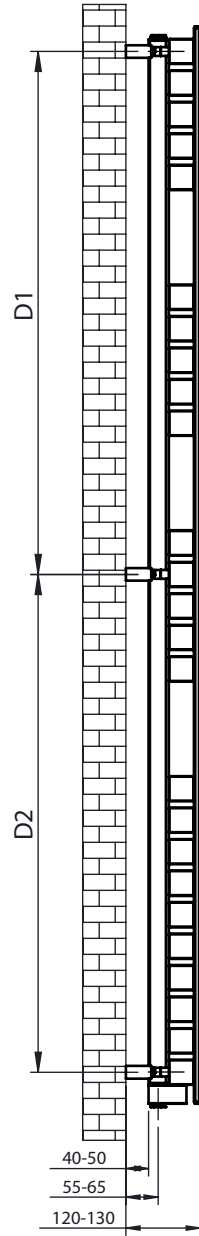
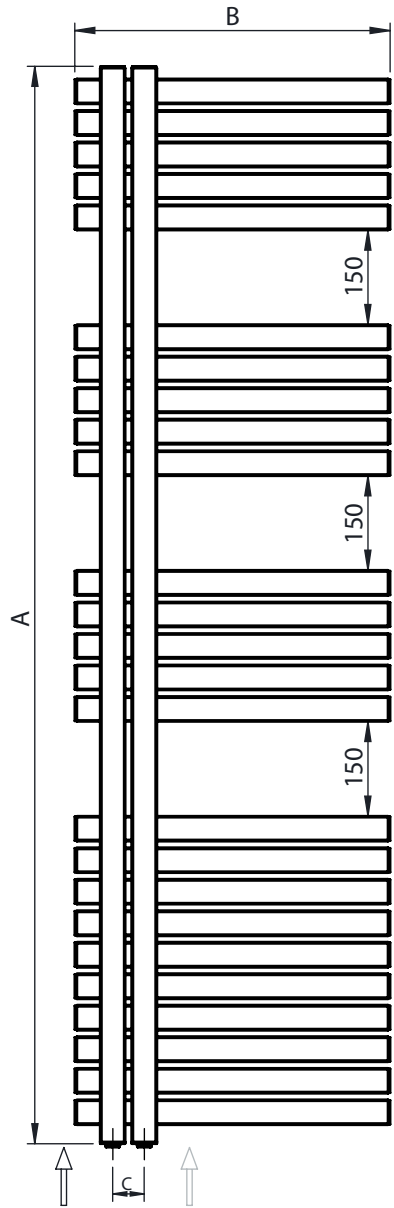

MODEL NAME	A HEIGHT mm	B LENGTH mm	C PIPE CENTER mm	D1-D2 VERTICAL BRACKET CENTERS mm	E HORIZONTAL BRACKET CENTERS mm	HEAT OUTPUTS (BTU) Delta T:50 °C	HEAT OUTPUTS (WATT) Delta T:50 °C
Proxima 18-R	1710	500	50	830-790	115	6660	1950

Bracket Assembly

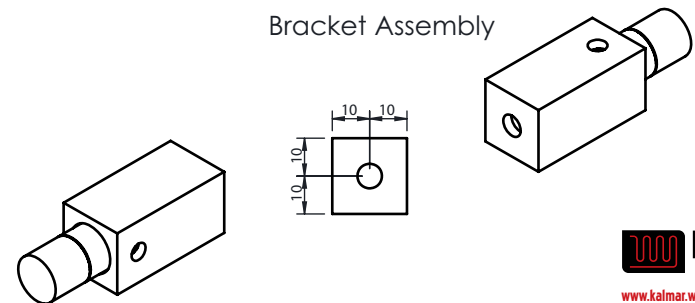

Fitting Instruction-Proxima L

Code:01.08.006-01

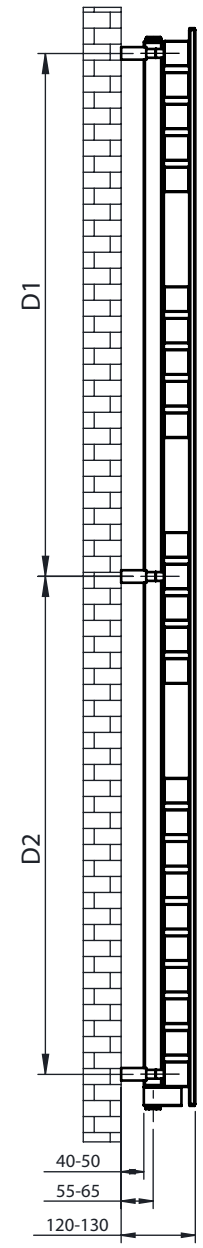
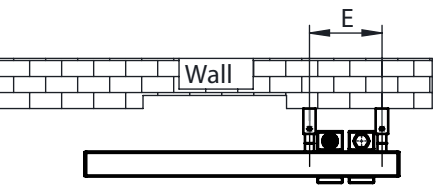
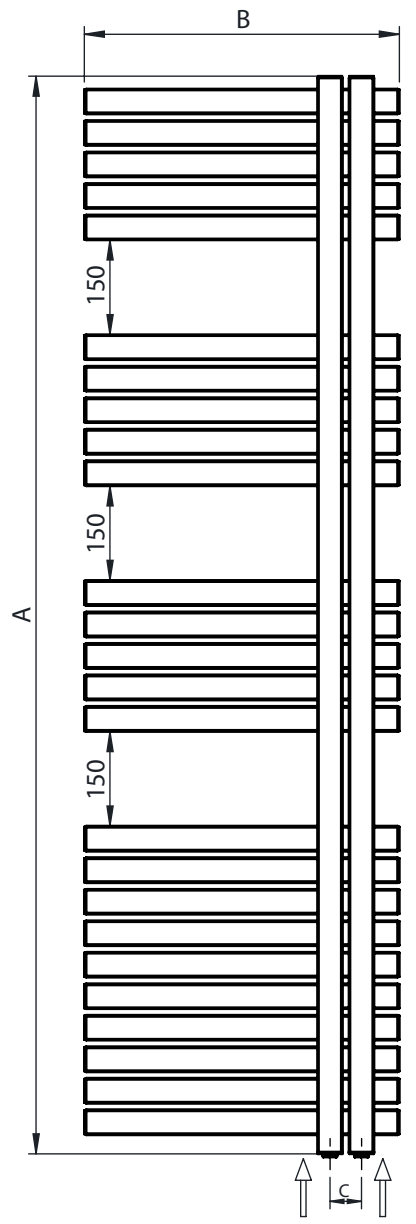

MODEL NAME	A HEIGHT mm	B LENGTH mm	C PIPE CENTER mm	D1-D2 VERTICAL BRACKET CENTERS mm	E HORIZONTAL BRACKET CENTERS mm	HEAT OUTPUTS (BTU) Delta T:50 °C	HEAT OUTPUTS (WATT) Delta T:50 °C
Proxima 18-L	1710	500	50	830-790	115	6660	1950

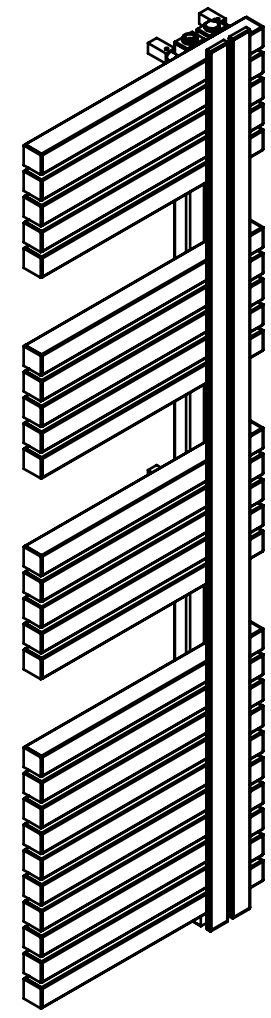

Bracket Assembly

